

DEMOCRATIC SOCIALIST REPUBLIC OF SRI LANKA

MINISTRY OF HEALTH, NUTRITION & INDIGENOUS MEDICINE

TEACHING HOSPITAL, PERADENIYA

**PROPOSED NEW STORM DISPOSAL DRAIN FOR
EXCESS WATER POND-UP NEAR BLOOD BANK**

BIDDING DOCUMENT

Volume I

Invitation for Bids

- Section 01 - Instructions to Bidders**
Section 02 - Standard Form
Section 03 - Conditions of Contract
Section 04 - Form of Bid and Qualification Information
Section 05 - Schedules
Section 06 - Specifications
Section 07 - Bill of Quantities

Contractor

CONSULTANT

CENTRAL ENGINEERING CONSULTANCY BUREAU
415, BAUDDHALOKA MAWATHA,
COLOMBO 07.

CLIENT

MINISTRY OF HEALTH, NUTRITION & INDIGENOUS MEDICINE
“ SUWASIRIPAYA “,
385, REV BADDEGAMA WIMLAWANSA THERO
MAWATHA,
COLOMBO 10.

C O N T E N T S

	Page
Invitation for Bids	2
Section 1 - Instructions to Bidders	5
Section 2 - Standard Forms(Contract)	7
Standard Form: Letter of Acceptance	9
Standard Form: Agreement	10
Standard Form: Performance security	12
Standard Form: Advance payment security	13
Standard Form: Retention Money Guarantee	15
Section 3 - Conditions of Contract	16
Section 4 - Form of Bid and Qualification Information	18
Form of Bid	19
Qualification Information	20
Section 5 - Schedule	21
Section 6 - Specifications	27
Section 7 - Bill of Quantities Technical and Other Schedules	29
Preambles to Bill of Quantities	30
Bill of Quantities	
Technical and Other Schedules	
Section 9 - Standard Forms (Bid)	32
Check List for Bidders	35

INVITATION FOR BIDS

1. INVITATION FOR BIDS (IFB)

MINISTRY OF HEALTH

TEACHING HOSPITAL PERADENIYA

**PROPOSED NEW STORM DISPOSAL DRAIN FOR EXCESS WATER POND-UP NEAR
BLOOD BANK**

(Contract No:)

1. The Chairman, Regional Procurement committee, Teaching Hospital Peradeniya on behalf of the Teaching Hospital, Peradeniya now invites sealed bids for **Proposed New Storm Disposal Drain for Excess Water Pond-Up Near Blood Bank** as described below and estimated to cost Rupees 9.5M. (excluding VAT & Contingencies).

The Site is Located at the premises of Teaching Hospital, Peradeniya. Work to be carried out are mainly comprise of construction of storm disposal drain...etc. (For more detail refer BOQ). The contract period will be 90 Days.

2. Bidding will be conducted through National Competitive Bidding Procedure.

3. To be eligible for contract award, the successful bidder shall not have been blacklisted and shall meet the following requirements.

CIDA (ICTAD) Registration Required:

Speciality: **Building**

Grade : **C7 or C6**

4. Qualification requirements to qualify for contract award include:

- (a) Technical staff at site to be

1. One Technical Assistant (Civil, full time on site) – NCT or equivalent with 3 year experience.

- (b) Contractor has successfully completed at least two projects similar to this by value and complexity during last five years

- (c) As the estimate cost for the procurement exceeds the Rs.5 million the bidder shall register at the registrar of Public Contract Sri Lanka at the time of submission of bids (PCA 3) and forward the certificate

5. You may obtain further information from Director, Teaching Hospital, Peradeniya, Tel. No. 081 - 3990312 and inspect the bidding documents at the address given below from 09.00 hrs to 14.00 hrs.

6. A complete set of Bidding Documents in English language may be purchased by you on the submission of a written application to the address given below, from 2025.02.14 until

2025.03.07 from 09.00 hrs to 14.00 hrs or download the bidding document browsing www.peradeniya-hospital.health.gov.lk upon payment of a non-refundable fee of Rs. 2,500.00

7. Bids shall be delivered to the address below on or before 14.00 hrs on 2025.03.07. Late bids will be rejected. Bids will be opened soon after closing in the presence of the bidders' representatives who choose to attend.
8. All bids shall be accompanied by a Bid Security of Rupees **one hundred twenty thousand (Rs 120,000.00) only**. The Bid Security shall be valid up to **105 Days** from the closing date of the bid (including closing date of bid).
9. Bids shall be valid up to 77 Days.
10. The addressed referred to above is,
Chairman,
Regional Procurement committee,
Teaching Hospital
Peradeniya,
Tel 081 - 3990312

SECTION – 1

INSTRUCTIONS TO BIDDERS

Notes:

Instructions to Bidders shall be read in conjunction with Section 5 – Schedule given in Volume 2.

Instructions to Bidders will not be a part of the Contract and will cease to have effect once the Contract is signed.

INSTRUCTIONS TO BIDDERS

Instruction to Bidders applicable to this contract is those given in Section 1 of the Standard Bidding Document for procurement of works Minor Contracts. ICTAD publication No.ICTAD/SBD/03, Second Edition ,January 2007, published by the Construction Industry Development Authority (CIDA).

This publication will not be issued with the bidding Document and the bidder is advised to purchase it from CIDA.

Instructions to Bidders shall be read in conjunction with the schedule provided under Section 5 of the Bidding Document.

Instruction to Bidders will not be a part of the contract.

SECTION – 2

STANDARD FORMS (CONTRACT)

*Letter of Acceptance, Form of Agreement,
Forms of Performance Security, Form of Advance Payment Security
And*

Form of Retention Money Guarantee

Notes on Standard Forms:

- *Bidders shall submit the completed Form of Bid Security in compliance with the requirements of the bidding documents.*
- *Bidders should not complete the Form of Agreement at the time of preparing of bids.*
- *The successful Bidder will be required to sign the Form of Agreement, after the award of contract.*
- *Any corrections or modifications to the accepted bid resulting from arithmetic corrections, acceptable deviations, or quantity variations in accordance with the requirements of the bidding documents should be incorporated into the Agreement.*
- *The Form of Performance Security, Form of Advance Payment Security and Form of Retention Money Guarantee should not be completed by the Bidders at the time of preparation of bids.*
- *The successful Bidder will be required to provide these securities in compliance with the requirements herein or as acceptable to the Employer.*

Notes on From of Letter of Acceptance

The Letter of Acceptance will be the basis for formation of the Contract as described in Clause 30 of the Instructions to Bidders. This From of Letter of Acceptance should be filled in and sent to the successful bidder only after evaluation of Bids and after obtaining approval from the relevant authority.

FORM OF LETTER OF ACCEPTANCE

(Letter head paper of the Employer)

..... *(Date)*

To:

(Name of the Contractor)

.....

(Address of the Contractor)

*This is to notify you that your Bid datedto execute, complete, remedy any defects therein and maintain the **Proposed New Storm Disposal Drain for Excess Water Pond-Up Near Blood Bank**, Contract No..... for the Contract price of Rupees
..... *(Amount in figures and words) as corrected in accordance with Instructions to Bidders and / or modified by a Memorandum of Understanding (if any), is hereby accepted.**

The adjudicator shall be/ shall be appointed by the Construction Industry Development Authority (CIDA).

You are hereby instructed to proceed with the execution of the said works in accordance with the Contract documents.

The Start Date shall be: (Fill as per Clause 6.1 of Conditions of Contract).

The amount of Performance Security is: (Fill as per Clause 4.4 of Conditions of Contract).

The deadline for submission of Performance Security is (Fill as per Clause 4.4 of Conditions of Contract).

Authorized Signature:

Name and title of Signatory:

.....
Name of Agency:

FORM OF AGREEMENT

This Agreement made the (Day) of (Month) 2025, between Director, Teaching Hospital, Peradeniya. (Hereinafter called and referred to as “the Employer”), of the one part, and
..... (Name and address of Contractor)
(Hereinafter called and referred to as “the Contractor”), of the other part:

Whereas the Employer desires that the Contractor execute **Proposed New Storm Disposal Drain for Excess Water Pond-Up Near Blood Bank** (hereinafter called and referred to as “the Works”) and the Employer has accepted the Bid by the Contractor for the execution and completion of such Works and remedying of any defects therein.

The Employer and the Contractor agree as follows:

1. In this Agreement words and expressions shall have the same meanings as are respectively assigned to them in the Contract hereinafter referred to.
2. In consideration of the payments to be made by the Employer to the Contractor as indicated in this Agreement, the Contractor hereby covenants with the Employer to execute and complete the Works and remedy any defects therein in conformity in all respects with the provisions of the Contract.
3. The Employer hereby covenants to pay the Contractor in consideration of the execute and complete the Works and remedy any defects therein, the Contract Price or such other sum as may become payable under the provisions of the Contract at the times and in the manner prescribed by the Contract.

In Witness where of the parties hereto have caused this Agreement to be executed the day and year first before written in accordance with laws of Sri Lanka.

.....
Authorized signature of Contractor

.....
Authorized signature of Employer

COMMON SEAL

COMMON SEAL

In the presence of:

Witnesses:

1. Name and NIC No.

Signature

Address

2. Name and NIC No.

Signature

Address

FORM OF PERFORMANCE SECURITY

(Unconditional)

.....
[Name and Address of Issuing Branch or office]

Beneficiary: Director,
Teaching Hospital
Peradeniya.

Date:

PERFORMANCE GUARANTEE No:.....

We have been informed that *[Name of Contractor]*
(Hereinafter called to “**the Contractor**”) has entered into Contract No., dated
..... with you, for the **Proposed New Storm Disposal Drain
for Excess Water Pond-Up Near Blood Bank** Teaching Hospital- Peradeniya (Contract No:
.....) (hereinafter called to “**the Contract**”).

Furthermore, we understand that, according to the conditions of the Contract, a performance guarantee is required.

At the request of the Contractor, we
.....*[Name of
the Agency]* hereby irrevocably undertake to pay you any sum or sums not exceeding in total an
amount of*[amount in
figures]*(.....) *[amount in words]*, upon receipt by us of your
first demand in writing accompanied by a written statement stating that the Contractor is in breach of
its obligation(s) under the Contract, without your needing to prove or to show grounds for your
demand or the sum specified therein.

This guarantee shall expire, no later than theday of, 20.....*[date, 28 days beyond the
Intended Completion Date]* and any demand for payment under it must be received by us at this office
on or before that date.

[Signature (s)]

FORM OF GUARANTEE FOR MOBILIZATION ADVANCE PAYMENT

BOND
DATE.....
SUM GUARANTEED:

NUMBER:

Beneficiary: Director,
Teaching Hospital,
Peradeniya.

Name of the Contract: Proposed New Storm Disposal Drain for Excess Water Pond-Up Near Blood Bank

In accordance with the provisions of the Conditions of Contract, of the above mentioned contract.....
(Name and address of Contractor) [hereafter called “the contractor”] shall deposit with the Director, Teaching Hospital, Peradeniya a bank guarantee or reputed Insurance Company guarantee to guarantee his proper and faithful performance under the said Contract in an amount of(amount of guarantee)(amount in words).

We, the..... (Bank or reputed Insurance Company, operating in Sri Lanka), as instructed by the contractor, agree unconditionally and irrevocably to guarantee as primary obligator and not as surety merely, the payment to the Director, Teaching Hospital, Peradeniya on his first demand without whatsoever right of objection on our part and without his first claim to the Contractor, in the amount not exceeding.....(amount of guarantee),(amounts in wards) such amount to be reduced periodically by the amounts recovered by you from the proceeds of the contract.

We further agree that no change or addition to or other modification of the terms of the Contract or of the Works to be performed thereunder or of any of the Contract Document which may be made between you and the Contractor shall in any way release us from any inability under this guarantee, and we hereby waive notice or any such change, addition or modification.

No drawing may be made by you under this guarantee until we have received notice in writing from you that an advance payment of the amount listed above has been paid to the Contractors pursuant to the Contract.

This guarantee shall remain valid and in full effect from the date of the advance payment under the Contract until the Director, Teaching Hospital, Peradeniya received full payment of the same amount

from the Contractor.

Signature and the Seal of the Guarantor:

Name of the Bank:

Address:

Date:

Witness:

FORM OF RETENTION MONEY GUARANTEE

NUMBER:

DATE:

SUM GUARANTEED:

To:
Director,
Teaching Hospital,
Peradeniya.

(Hereinafter called and referred to as “the Employer”)

Name of the Contract **Proposed New Storm Disposal Drain for Excess Water Pond-Up Near Blood Bank.** Whereas, it has been stipulated by the Employer in clause 10.5 of the Conditions of Contract that he would release to the contractor the full sum mentioned under the contract in pursuance of clause 10.5, on the contractor furnishing an unconditional guarantee acceptable to the Employer to the full value of the retention money, valid up to 28 days beyond the end of the Defects Notification Period.

We (name and address of the Guarantor) as instructed by the Contractor, unconditionally and irrevocably, guarantee to pay the Employer upon the Employer’s first written-demand and without cavil or objection, any sum or sums within the said amount as aforesaid without the Employer’s needing to prove or to show grounds or reasons for the Employer’s demand for the sum specified therein and the said amount of Rupees (Amount of Guarantee) (Amount in words) in the event the contractor fails to carry out his obligations to rectify defects which he is responsible to rectify under the contract.

This guarantee shall be valid up-to (Date)

Signature and Seal of the Guarantor

Name of Bank

Address

Date

Witness

SECTION - 3

CONDITIONS OF CONTRACT

Conditions of Contract shall be read in conjunction with Schedule

Note - Conditions of Contract shall be read in conjunction with Schedule

CONDITIONS OF CONTRACT

Conditions of Contract that will be applicable for this Contract shall be that given in Section 3 of the Standard Bidding Document for Procurement of Works - Minor Contracts, ICTAD Publication No. ICTAD/SBD/03, Second Edition, January 2007, published by the Construction Industry Development Authority (CIDA).

The above publication will not be issued with the Bidding Document and Bidder is advised to purchase it from CIDA.

This Conditions of Contract shall be read in conjunction with “**Schedule for Conditions of Contract**” attached herewith.

SECTION – 4

**FORM OF BID AND QUALIFICATION
INFORMATION**

FORM OF BID

Name of Contract: **Proposed New Storm Disposal Drain for Excess Water Pond-Up Near Blood Bank**

To: Director,
Teaching Hospital,
Peradeniya.

Gentlemen,

1. Having examined the Conditions of Contract given in the Standard Bidding Document – Procurement of Works – Minor Contracts (ICTAD/SBD/03- Second Edition, January 2007 & Addendum 01 issued in January 2009), Schedule, Specifications, Bill of Quantities, Drawings and Addenda for the execution of the above named Works, we the undersigned, offer to execute and complete such Works and remedy any defect therein in conformity with the aforesaid Conditions of Contract, Schedule, Specifications, Bill of Quantities, Drawings and Addenda for the sum of Sri Lankan Rupees (without VAT)..... (SL Rs.), or such other sums as may be ascertained in accordance with the said Conditions.
2. We acknowledge that the “Schedule” forms part of our Bid.
3. We undertake, if our Bid is accepted, to commence the Works as stipulated in the Schedule, and to complete the whole of the Works comprised in the Contract within the time stated in the Schedule.
4. We agree to abide by this Bid for a period of 77 days from the date fixed for receiving, or any extended period, and it shall remain binding upon us and may be accepted at any time before the expiration of that period.
5. Unless and until a formal Agreement is prepared and executed, this Bid together with your written acceptance thereof, shall constitute a binding contract between us.
6. We understand that you are not bound to accept the lowest or any Bid you may receive.

Dated this day of 2025 in the capacity of
, duly authorized to sign Bids for and on behalf of
 (IN BLOCK CAPITALS)

Signature:

Address:

.....

Witness:

QUALIFICATION INFORMATION

(To be completed by the Bidder and submitted with the bid)

	Eligibility Requirement	Bidder's Qualification
ICTAD(CIDA) Registration	<i>(attach copies of relevant pages from the registration book)</i>	
Registration Number		
Grade	C7 or C6	
Specialty	Building	
Expiry Date		
Blacklisted Contractors		
Have you been declared as a defaulted contractor by NPA or any Agency?		Yes / No
If yes provide details		
VAT Registration Number *		
Construction program	<i>(attach as annex)</i>	
Legal Status	<i>(Public company / Private company / Partnership / Sole proprietor) - attach relevant copies as annex</i>	
	Eligibility Requirement	Bidder's Qualification
Qualification an experience of key staff (attach relevant certificates)	Category, Experiences and Qualifications	Required Nos.
	Technical Assistant (civil – full time in site) – NCT or equivalent with 03 year	
		Proposed by bidder (Name. Experience and Qualifications)

	experience.		
Value of similar works completed in last 5 years (Indicate only three largest projects)	1. Value Rs..... Year 2. Value Rs..... Year 3. Value Rs..... Year (Attach certified copies of certificate of completion)		
As the estimate cost for the procurement exceeds the Rs.5 million the bidder shall register at the registrar of Public Contract Sri Lanka at the time of submission of bids (PCA 3) and forward the certificate			

Signature of the Bidder:

SECTION - 5

SCHEDULE

Note:

This section shall be read in conjunction with section I – Instruction to Bidders and Section 3 – Conditions of Contract, and is intended to provide specific information in relation to corresponding Clauses in Section I & 3. Whenever there is an ambiguity, the provisions in Section 5 – Schedule shall supersede these provided in the Section I – Instructions to Bidders and Section 3 - Conditions of Contract.

SCHEDULE

ITB Clause	Conditions of Contract Clause	Item	Data
1.	1.1.8	Employer is:	Secretary, Ministry of Health, Nutrition & Indegenous Medicine 385, Rev. Baddegama Wimalawansa Thero Mawatha,. Colombo 10.
		Employer's Representative:	Director, Teaching Hospital, Peradeniya.
	1.1.10	Engineer is:	General Manager Central Engineering Consultancy Bureau, No.415, Bauddhaloka Mawatha, Colombo 07.
		Engineer's Representative:	Project Manager (HCW), Central Engineering Consultancy Bureau, Rajawella, Digana.
1. & 13.		Summary of Work:	Work to be carried out are mainly comprise of construction of storm disposal drain...etc (For more detail refer BOQ)

1.1.21 Located at: TeachingHospital, Peradeniya

Contract Name: **Proposed New Storm Disposal Drain for Excess Water Pond-Up Near Blood Bank**

Bid Validity : Bid Validity Period is 77 days from closing date of the Bid.

1. **1.1.14 Intended Completion Date** Intended Completion Date is: 90 Days from starting date
2. **Source Of Funds** The Source of Funds is GOSL
3. **Eligibility** The requirement is; registered with the Construction Industry Development Authority (CIDA/ICTAD), under the
Grade :- **C7 or C6**
Specialty :- Building works

8.

The set of bidding document shall be comprised with the documents listed below;

Volume I – One bound document consist of one copy each of following sections,

Invitation for Bids

Section 01 – Instructions to Bidders

Section 02 – Standard Forms

Section 03 – Conditions of Contract

Section 04 – Form of Bid and Qualification

Information

Section 05 – Schedules

Section 06 – Specifications

Section 07 – Bill of Quantities

Section 08 - Drawings

Volume II – Two separate bound documents, each consist of one Copy of following sections,

Invitation for Bids

Section 04 – Form of Bid and Qualification

Information

Section 07 – Bill of Quantities

12

(A) Enclosed in the envelope marked as “ORIGINAL”;

(a) Fully bound Volume 1

(b) Bid Security

Bidder shall complete the schedules attached in the section 07

And

(B) Enclosed in the envelope marked as “COPY”

(a) One copy of fully bound Volume II

The Bidders may retain the Balance copy of Volume II, which consist of Section 4, Section 5 and Section 7.

13. 10.10 **Price Adjustment** The Contract is not subjected to price adjustment

16. **Bid Security** The amount of Bid Security shall be Sri Lanka Rupees **one hundred twenty thousand (Rs 120,000.00)** only.

Bid Security Validity Period The Bid Security shall be valid up to 105 Days from the closing date of the Bid.

Securities and Guarantees issued by the following institutions are acceptable:

1. A Bank operating in Sri Lanka, approved by the Central Bank of Sri Lanka.
2. A reputed Insurance Company operating in Sri Lanka accepted by the Treasury for acceptance of Guarantees.
3. Construction Guarantee fund.

Alternatively, the Tenderer can pay cash to Shroff of the Teaching Hospital, Peradeniya.

No interests will be paid on cash deposits

17. **Pre Bid meeting** will be held at **Conference Room No. 02, Teaching Hospital – Peradeniya** at **10.30** hrs on **2025.02.21**

31. 4.4 **Performance Security** Amount of performance security required is 5% of Initial Contract Price.

Securities and Guarantees issued by the following institutions are acceptable:

1. A Bank operating in Sri Lanka, approved by the

Central Bank of Sri Lanka.

2. A reputed Insurance Company operating in Sri Lanka accepted by the Treasury for acceptance of Guarantees.
3. Construction Guarantee Fund

Also, the Tenderer can paid cash to Shroff of the Teaching Hospital, Peradeniya.

No interests will be paid on cash deposits.

6.4	Late Completion	the amount to be paid is 0.05% of initial contract price per Day, subjected to Maximum of 10% of Initial Contract Price.
8.1	Notification Of Defects	The period for Defects Notification is 365 Days from Taking Over.
10.3	Retention	The retention from each payment Shall be 10% of the work done, as per The Interim Certificate. The Limit of maximum amount of retention is 5% of Initial Contract Price.
13.1(c)	Insurance, Third Party	Minimum amount for third party insurance is Rs. 50,000.00 per Occurrence with the number of Occurrences unlimited
13 (d)	Insurance for Employer and Contractor's Personnel	Minimum amount for Insurance for Employer and Contractor's Personnel is Rupees Fifty thousand (Rs.50, 000.00)
33.	1.1.11	Adjudicator Fees and types of reimbursable expenses to be paid to the Adjudicator Shall be on a case to case basis
	14.0	Resolution of Disputes and shall be shared by the Contractor and the Employer

15 ADDITIONAL CLAUSES

15.1

Value Added

Taxes (VAT) VAT component shall not be included in the rates. The amount written in the Form of Tender shall be without VAT.

If Bidder is registered for VAT, the Bidder shall indicate the amount of VAT claimed separately at the end of the Bill of Quantities, in addition to the net value of the Bid, along with VAT registration number. The amount written on the Form of Bid shall be without VAT. Any Bidder who does not declare his VAT registration number will be liable for rejection of his Bid.

If any Bidder is not registered for VAT, he shall indicate the net value of the Bid. Under this category Bidder shall obtain a letter from the Commissioner of Inland Revenue Department, certifying the Company has not been registered for VAT, shall be attached to the Bid. Any Bidder who does not comply with this requirement will be liable for rejection of his Bid

The same VAT percentage will be applicable to any Extra works and variation.

- **No advance payment will be made.**

SECTION - 6

SPECIFICATIONS

SPECIFICATIONS

The Works under this Contract shall be executed in accordance with the Specifications given in the following documents issued by the Institute for Construction Training and Development (ICTAD), “Savsiripaya”, 123, Wijerama Mawatha, Colombo 07.

<u>Publication No.:</u>	<u>Description:</u>
SCA/4(Vol. I)	Specifications for Building Works, Vol. (I), Sri Lanka. 3 rd Edition (Revised), July 2004.
SCA/4(Vol. II)	Specifications for Building Works Vol. (II), Sri Lanka. 2 nd Edition (Revised) October 2001.
SCA/3/2	Specifications for Water Supply Sewerage and Storm Water Drainage Works, Sri Lanka. Second Edition (Revised), April 2002.
SCA/8	Specifications for Electrical and Mechanical works associated With Building and Civil Engineering, Sri Lanka. Second Edition (Revised), August 2000.

It is implied that the eligible Tenderers are fully acquainted with the above documents and therefore, those will not be issued to the Tenderers in this Tender.

However, the Tenderers may purchase the same if necessary from CIDA. “Savsiripaya”, 123,

Wijerama Mawatha, Colombo 07.

SECTION - 7

BILL OF QUANTITIES

PROPOSED NEW STORM DISPOSAL DRAIN FOR EXCESS WATER POND-UP
NEAR BLOOD BANK
GENERAL HOSPITAL (TEACHING) - PERADENIYA

SUMMARY

ITEM	DESCRIPTION	AMOUNT Rs. Cts.
A	PRELIMINARIES	
B	SITE PREPERATION	
C	CONCRETER	
D	MISCELLANEOUS WORKS	
(a)	Sub Total I	
(b)	Ddt: Provisional Sum	544,000.00
(c)	Sub Total II	
(d)	Ddt :% Discount	
(e)	Sub Total III	
(f)	Add: Provisional Sum	544,000.00
(g)	Total amount for Bid	
(h)	Add : 18% VAT	
(j)	Total Amount with VAT	

Total Sum carried to Form of bid in words Rupees (without VAT)

.....

Signature of the Contractor

Witness :-

Address

Address :-

Date

Date :-

PROPOSED NEW STORM DISPOSAL DRAIN FOR EXCESS WATER POND-UP NEAR BLOOD

BANK

GENERAL HOSPITAL (TEACHING) - PERADENIYA

PRELIMINARIES

Note:

- 1 The Engineer/ Consultant may modify or amended any item , or delete inappropriate item/s or add new item/s , depending on the nature of the proposed work.
- 2 Mode of payment are as below.

Mode of Payment	Category
Reimbursement of actual cost on submission of the relevant document acceptable to the Engineer plus 5% of the actual cost of obtaining the insurance policies and securities.	A
60% on completion of temporary buildings or structures. 30% in equal installments over the contract period and balance 10% on dismantling and removal on completion.	C
Paid on satisfactory completion of the item	D
In equal installments over the contract period.	E
Mode of payment to be mutually agreed between contractor and the employer at the commencement of contract in relation to the program of work.	F
On the completion of work	G

- 3 The above recommended percentage may be adjusted by the Employer/Consultant to suit the particular project.
- 4 The tenderer is advised to visit the site of the proposed work, as it is his responsibility to ascertain the conditions, space governing access to the site, external working space, storage area, status of the adjoining properties etc.
- 5 Any preliminary item not listed below but deemed to be included in the tender rates, as no extras would be made.

Item	Description	Mode of payment Category	Unit	Amount Rs. Cts.
A	<u>PRELIMINARIES</u>			
	Insurance & Securities			
A1	Provisional Sum for providing a Performance Security	A	P.S	19,000.00
A2	Provisional Sum for providing an Advance Payment Security	A	P.S	30,000.00
A3	Provisional Sum for insurance of Works, Machinery & Equipment, Plant, Materials, third party persons & property at site as per the Contract. (All Risk Policy)	A	P.S	20,000.00
A4	Provisional Sum for insurance against accidents and injury to Contractor's personel as per the Contract. (Workmen Compensation)	A	P.S	10,000.00

	Contractor's Facilities			
A5	Allow lump sum for constructing, maintaining, dismantling and removal on completion of the Works, a <u>temporary site office</u> , stores of adequate size including staff rest room and toilets and other facilities for the Contractor's site management staff in accordance with the plans prepared by the Contractor and concurred by the Engineer.	C	Item	
	Setting Out			
A6	Setting out of Works in accordance with drawing and other written information given by Engineer.	F	Item	
	Quality, Standards and Progress			
A7	Allow lump sum for provision of 3 sets of (Hard copies and soft copies) as built drawings of all services, for Engineer's approval.	D	Item	
	Health, Safety & Environment			
A8	Allow lump sum for providing all necessary safety measures to workmen at site conforming to the latest industrial safety regulations and as directed by the Engineer.	E	Item	
A9	Allow lump sum for maintaining the site in a clean and orderly manner at all times and during the entire contract period, demobilization, removal of all rubbish, debris and clearing up site on completion, leaving all in good order and handing over.	G	Item	
	Services & Facilities			
A10	Allow lump sum for supply of water for the works and paying all charges and other expenses in connection with the supply from water mains or any other alternative method of water supply, storage and reticulation.	E	L. Sum	
	Sub Total carried to Grand Summary			

**PROPOSED NEW STORM DISPOSAL DRAIN FOR EXCESS WATER POND-UP NEAR BLOOD BANK
GENERAL HOSPITAL (TEACHING) - PERADENIYA**

Item	Description	Unit	Qty.	Rate (Rs.)	Amount (Rs.)
B	<u>SITE PREPERATION</u>				
	<i>Rates are included for clearing away and dumping / stacking debris within the Hospital Premises as instructed by the Engineer unless stated otherwise. Reusable / serviceable material shall be handed over to the client in formal way. Clearing away debris from the Hospital Premises is paid separately and unless stacked calculate.</i>				
B1	Demolishing, Hacking up & clearing debris away of floor paving brick or rubble inclusive of rendering.	m ²	150		
B2	Cutting existing asphalt layer by asphalt cutter.	m	50		
B3	Excavation in wells / pits in normal earth up to depth of 1.0m inclusive of backfilling behind wall / ring and disposal of surplus earth. (Manual Cutting)	m ³	150		
B4	Shoring for excavations (Trenches / Footings etc.) up to 1.5m height. (Using Timber planks)	m ²	225		
B5	Clearing away debris from hospital premises using tractor/trailer or tipper.	load	50		
	Sub Total carried to Summary				
C	<u>CONCRETER</u>				
	<i>Unless otherwise stated all concrete shall be of grade as per Specifications/Drawings.</i>				
	<i>Rates for concrete shall include for forming construction joints, expansion joints or contraction joints as necessary.</i>				
	<i>Concrete will be measured as the net area/volume, as shown on the drawings.</i>				
	<i>Rate for concrete shall include for :</i>				
	<i>supply, handling at site, mixing, depositing, compacting, vibrating, curing and making good after removal of formwork.</i>				
	<i>preparation of surfaces, roughening/chipping to the approval of the Engineer.</i>				
	<i>Reinforcement and Formwork paid separately unless specified in the Item.</i>				
	<i>Rate shall include for necessary tests including cube tests as per the BS 1881 and SCA/4/1.</i>				

Item	Description	Unit	Qty.	Rate (Rs.)	Amount (Rs.)
C1	Mixing and placing in position concrete 100mm thick grade 20, nominal mix 1:2:4 (20mm) using a concrete mixer including fuel / operator / handling/vibrator & curing.	m ³	85		
C2	Supplying, Laying & Jointing Type NP-2 600 mm Dia. Concrete Pipes (Hume) and Collars. All work done as per Engineer's Instruction.	m	150		
C3	Construction of manhole 600mm x 600mm x 600mm internally complete with cement concrete 1:2:4 (20mm) in 75mm thick base, 225mm to.brick walls on top of base slab and channelling & benching, 1:3 cement and sand rendered in internal surfaces, 75mm thick RC. cover slab r/f with 10mm tor steel @ 150mm c/c. both ways, complete with lifting handles.	nr	5		
C4	Construction of manhole 1.05m x 0.675m x 0.60m internally complete with cement concrete 1:2:4(20mm) in 75mm thick base, 225mm to.brick walls on top of base slab and channelling and benching, 1:3 cement and sand rendered in internal surfaces, 75mm thick R.C.C. cover slab r/f with 10mm tor steel @ 150mm c/c. both ways, complete with lifting handles.	nr	2		
C5	Lay Standard Type Road Kerbs (125mm x 900mm) Set on 19mm thick 1:3Cement Mortar Layer on 150mm x 275mm 1:2:4(19) Concrete Foundation With av. 157mm x 150mm Backing	m	50		
C6	Lay and Compact Asphalt Premix Usign Paver (Rate include for Cost of premix, Aggregate Transport and premix transport to vbe paid)	m ²	125		
C7	Paving available interlock blocks rough or smooth , gray colour nominal thickness 80mm with quarry dust bedding including compacting and levelling	m ²	150		
C8	Supplying & fixing 25mm Thick Planks and Struts of Class II Timber as Formwork Rough Finish, in Foundation Etc. Including Removing	m ²	250		
Sub Total carried to Summary					
D	<u>MISCELLANEOUS WORKS</u>				
D1	Preperation of cascade after cast manhole to drain along main road.	P.Sum			350,000.00
D2	Relocating or removing exisiting un-power armod cable and relaying after Hume pipe laying along tranch	P.Sum			100,000.00
D3	Supplying & Installation of Safety "CAUTION" Warning Tape (Yellow & Black Barricade Tape) for Danger/Hazardous/Isolating Areas.	P.Sum			15,000.00
Sub Total carried to Summary					465,000.00

PROPOSED NEW STORM DISPOSAL DRAIN FOR
EXCESS WATER POND-UP NEAR BLOOD BANK

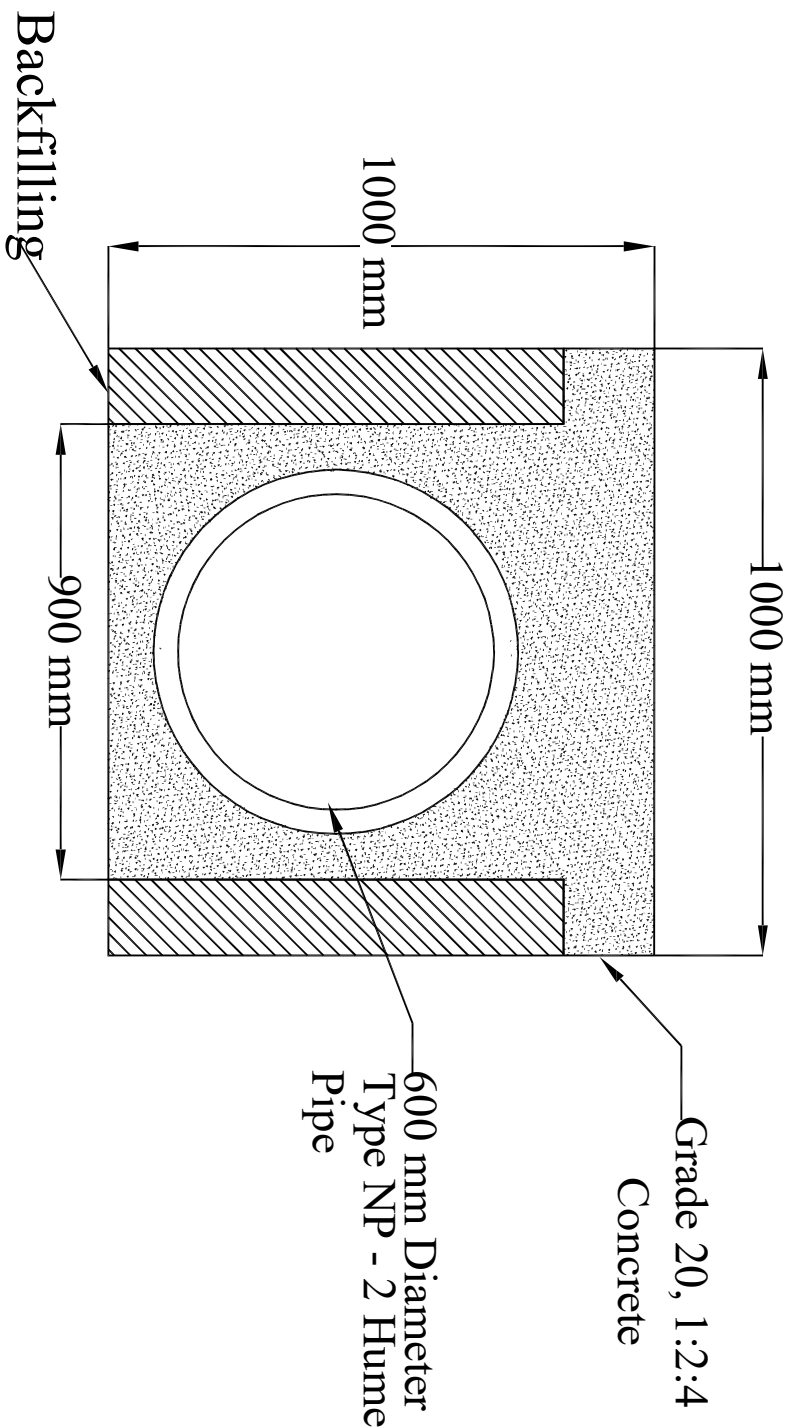

Section View

PREAMBLE TO THE BILL OF QUANTITIES

1. The Conditions of Contract, the Specifications are to be read in conjunction with the Bill of Quantities.
2. The cost of complying with all conditions, obligations and liabilities described in the Conditions of Contract and the Specifications and the Bill of Quantities **including all overhead charges (excluding VAT), profit and Preliminaries** and carrying out the work as described shall be deemed to be spread over and included in the prices or sums stated by the Bidder in the Bill of Quantities. VAT should be separately added.
3. If the Bidder failed to price any Items in the Bill of Quantities then the cost of the work under such Item shall be held to be spread over and included in the prices given against other Items of work.
4. When trade names, brand and/or catalogue numbers are referred to, sole preference to any material or equipment is not intended. Any other material or equipment may be used, provided that the characteristics of type, quality, appearance, finish, method of construction and/or performance is equal to or superior to specify.
5. Whenever the method of measurement is not clear from documents available, the principles as given in the Sri Lanka Standard 573, 1999, Method of Measurement of Building Work shall be applicable.
6. All items of work shall comply exactly with the Contract unless otherwise approved by the Engineer and the rates and sums inserted in the Bill of Quantities shall be deemed to apply to the work as specified. If, for his convenience or reasons of availability, the Contractor proposes and the Engineer approves the use or provision of alternative items, materials or method of working, or equivalent or superior quality to those specified in the Contract, the rates and sums inserted in the Bill of Quantities shall not in any case be increased as a result.
7. The quantities set out in the Bill of Quantities are provisional and cover the approximate scope of the work which is anticipated to be performed by the Contractor. The actual

quantities used for final measurement purposes will be determined by the Engineer by measurement of the work completed by the Contractor.

8. Where, for his own purposes or due to his own default, the Contractor carries out the Works in such a manner that the quantity of any Item of work in particular component to be measured for payment purposes differs from that directed by the Engineer, then payment shall be made according to the lesser of the actual quantity and that directed. An excess quantity in one part of the component shall not, however, be allowed to offset a deficit elsewhere in the same component for measurement purposes.
9. Where the determination for payment purposes of the quantity of any Item of work depends upon the measurement of existing features or ground levels and the like, then prior to carrying out any operations which might affect such measurement, the Contractor shall first take such levels and measurements as the Engineer may direct and, after the Engineer has had the opportunity to check the same, they shall be certified as agreed by both the Engineer and the Contractor.
10. In the event that the Contractor fails to observe the above procedure, the Engineer shall determine the quantity to be assumed for payment purposes using the best information available to him, and his decision in the matter shall be final.
11. Selected Bidder shall comply with the arrangement of work in the buildings and be ready to work part by part as required by the Authorities of Teaching Hospital, Peradeniya
12. Rates in the Bill of Quantities shall include all necessary materials such as cables, PVC conduits, PVC sunk boxes etc and labour required to complete the electrical installation to good working order.
13. Except where specifically stated, all costs associated with provision of all holes, openings, chases and ducts in other builders' work required for installation and make them good , shall be included in the rates.
14. Bidder should pay special attention to the work to be carried out, causing minimum disturbance or hindrance to the normal functions and activities of the users of the Teaching Hospital, Peradeniya
15. The Bills of Quantities should therefore, be priced to reflect all factors that would affect the bid and the progress of the works.
16. All electrical accessories should comply with relevant BS/IEC standards. For electrical accessories, manufacturer's guarantee should be produced if necessary.
17. The wiring installation shall comply with the requirements of IEE Wiring Regulations, latest edition.
18. Screens should be provided to prevent dust escaping from working areas.
19. Metric units are used throughout the Bill of Quantities for measurement purposes unless otherwise indicated. Abbreviations used in the Contract are as follows:-

mm - Millimeter

m	-	Linear meter
kg	-	Kilogram
m ²	-	Square meter
m ³	-	Cubic meter
nr	-	Number
Rs.	-	Sri Lankan Rupees
Cts.	-	Cents
P. S.	-	Provisional sum
L. S.	-	Lump Sum

SECTION - 9

STANDARD FORMS (BID)

- *Bidders shall submit the completed Form of Bid Security/Bid Securing Declaration as appropriate in compliance with the requirements of the bidding documents.*

FORM OF BID SECURITY

.....
[Insert issuing agency's name and address of issuing branch or office]

Beneficiary: Director,
Teaching Hospital,
Peradeniya.

Date: [Insert (by issuing agency) date]

We have been informed that *[Insert (by issuing agency) name of the bidder]* (Hereinafter called “**the Bidder**”) has submitted to you its bid dated [Insert (by issuing agency) date] (Hereinafter called “**the Bid**”) for execution of **Proposed New Storm Disposal Drain for Excess Water Pond-Up Near Blood Bank** (hereinafter called and referred to as “the Bid”).

Furthermore, we understand that, according to your conditions, Bids must be supported by a Bid Guarantee.

At the request of the Bidder, we *[Insert name of issuing agency]* hereby irrevocably undertake to pay you any sum or sums not exceeding in total an amount of *[Insert amount on figures]* *[insert amount in words]* upon receipt by us of your first demand in writing accompanied by a written statement stating that the bidder is in breach of its obligation(s) under the bid conditions, because the Bidder:

- (a) has withdrawn its Bid during the period of bid validity specified; or
- (b) does not accept the correction of errors in accordance with the Instructions to Bidders (hereinafter “the ITB”); or

- (c) having been notified of the acceptance of its Bid by the Employer during the period of bid validity, (i) fails to refuses to execute the Contract Form, if required, or (ii) fails to refuses to furnish a Performance Security, in accordance with the ITB.

This Guarantee shall expire:

- (a) if the Bidder is the successful bidder, upon our receipt of copies of the Contract signed by the bidder and the Performance Security issued to you by the Bidder; or
- (b) If the Bidder is not the successful bidder, upon the earlier of the successful bidder furnishing the performance security, otherwise it will remain in force up to 28 days beyond the validity of the bid. (.....)

Consequently, any demand for payment under this guarantee must be received by us at the office on or before that date.

.....
[Signature of authorized representative(s)]

.....
Common Seal
(Signature, Name, and Address)

Check List for Bidders

Bidders are advised to fill the following table:

ITEM	ITB Clause	Yes (tick)	REFERENCE
Form of Bid			
Addressed to the Employer?	18		
Completed?	18		
Signed?	18		
Bid securing Declaration form (if required)			
Properly filled and signed	16		
Bid Security (if required)			
Addressed to the Employer?	16		
Format as required?	16		
Issuing Agency as specified?	16		
Amount and currency as requested?	16		
Validity 28 days beyond the validity of Bid ?	16		
Qualification Information			
All relevant information completed?	4		
Signed?	4		

Addendum			
Contents of the addendum (if any) taken in to account?	10		
BID package			
All the documents given in ITB Clause 12 enclosed in the original and copy?	12		
ITB Clause 19 followed before Sealing the Bid Package?	19		